



# Series C81/C91 Standard Dual Beam Wire Wrap Edge-Grip Sockets

## FEATURES:

- Dual beam, edge-grip contacts provide high retention with positive wiping action.
- Removable cover provides lower profile.
- Side-to-side stackable.

## SPECIFICATIONS:

- Body is black UL 94V-0 Glass-filled 4/6 Nylon.
- Dual beam contact is Grade A Phosphor Bronze Alloy, 1/2 hard.
- Contact plating: (all over 50µ" [1.27µm] Nickel per SAE-AMS-QQ-N-290)  
Tin = 200µ" [5.08µm] min Matte Tin per ASTM B545-97.  
Tin/Lead = 50-150µ" [1.27-3.81µm] min. 90/10 Tin/Lead per MIL-P-81728.  
Gold = 10µ" [0.25µm] min. Gold per MIL-G-45204.
- Contact current rating=1.5 Amp.
- Contact resistance=20 mOhms initial.
- Insulation resistance=100 MOhms @ 500 VDC per MIL-STD-1344, method 3003.1.
- Dielectric withstanding voltage=1000 VAC.
- Operating temperature= -67°F to 221°F [-55°C to 105°C] Tin  
= -67°F to 257°F [-55°C to 125°C] Gold
- Solderability: MIL-STD-202, method 208 less heat aging.
- Accepts leads up to .011 x .018 ± .003 [.28 x .46 ± .08] or .021 [.53] diameter.
- Accepts leads .100-.200 [2.54-5.08] long with cover.

## MOUNTING CONSIDERATIONS:

- Suggested PCB hole size=.046± .002 [1.17 ± .05] dia.

## ALL DIMENSIONS: INCHES [MILLIMETERS]

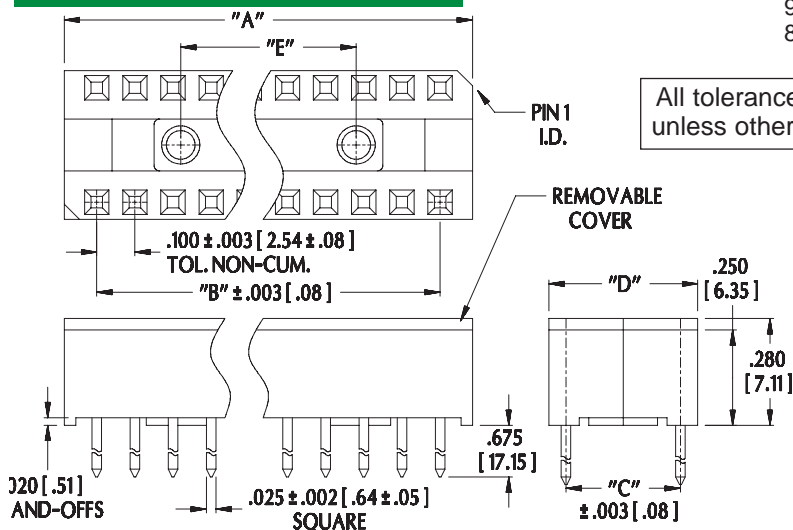

All tolerances ± .005 [.13] unless otherwise specified

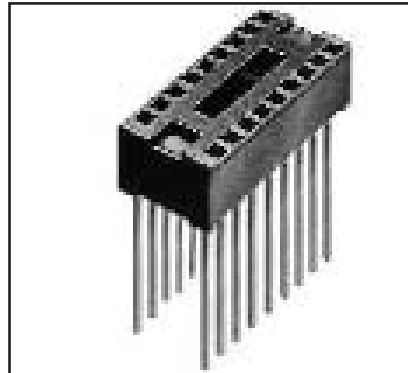

Note: Aries specializes in custom design and production. In addition to the standard products shown on this page, special materials, platings, sizes, and configurations can be furnished, depending on quantities. Aries reserves the right to change product specifications without notice.

## ORDERING INFORMATION

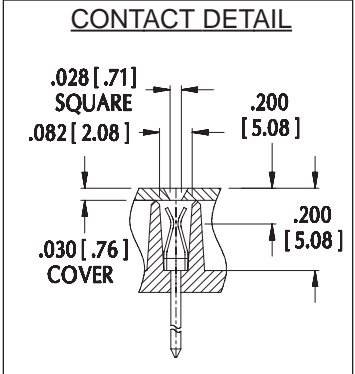
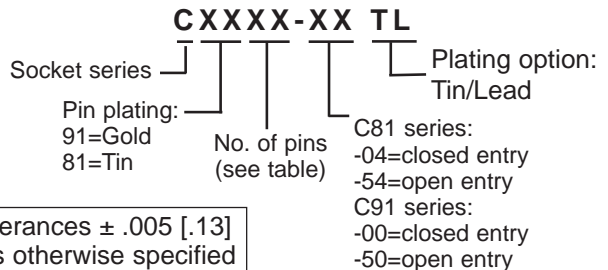

No. of Pins	Dim. "A"	Dim. "B"	Centers "C"	Dim. "D" (max)	Dim. "E"
8	.465 [11.81]	.300 [7.62]	.300 [7.62]	.400 [10.16]	---
14	.765 [19.43]	.600 [15.24]	.300 [7.62]	.400 [10.16]	.300 [7.62]
16	.865 [21.97]	.700 [17.78]	.300 [7.62]	.400 [10.16]	.400 [10.16]
18	.965 [24.51]	.800 [20.32]	.300 [7.62]	.400 [10.16]	.400 [10.16]
20	1.065 [27.05]	.900 [22.86]	.300 [7.62]	.400 [10.16]	.400 [10.16]
22	1.180 [29.97]	1.000 [25.40]	.400 [10.16]	.500 [12.70]	.500 [12.70]
24	1.280 [32.51]	1.100 [27.94]	.600 [15.24]	.700 [17.78]	.500 [12.70]
28	1.480 [37.59]	1.300 [33.02]	.600 [15.24]	.700 [17.78]	.500 [12.70]
36	1.880 [47.75]	1.700 [43.18]	.600 [15.24]	.700 [17.78]	.800 [20.32]
40	2.080 [52.83]	1.900 [48.26]	.600 [15.24]	.700 [17.78]	.800 [20.32]



Frenchtown, NJ USA  
TEL: (908) 996-6841  
FAX: (908) 996-3891



12003 REV.C