



STL100NH3LL

N-channel 30V - 0.0032Ω - 25A - PowerFLAT™ (6x5)
STripFET™ III Power MOSFET

Features

Type	V _{DSS}	R _{DS(on)} (max)	I _D
STL100NH3LL	30 V	<0.0035 Ω	25A ⁽¹⁾

1. The value is rated according R_{thj-pcb}

- Improved die-to-footprint ratio
- Very low profile package (1 mm max)
- Very low thermal resistance
- Conduction losses reduced
- Switching losses reduced

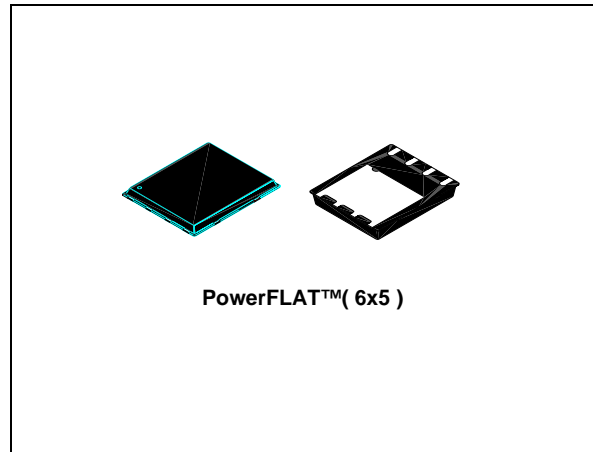

Application

- Switching applications

Description

This series utilizes the last advanced design rules of ST's proprietary STripFET™ technology. This process complete to unique metallization technique realised the most advanced low voltage Power MOSFET in PowerFLAT™(6x5). The Chip-scaled PowerFLAT™ package allows a significant board space saving, still boosting the performance.

Figure 1. Internal schematic diagram

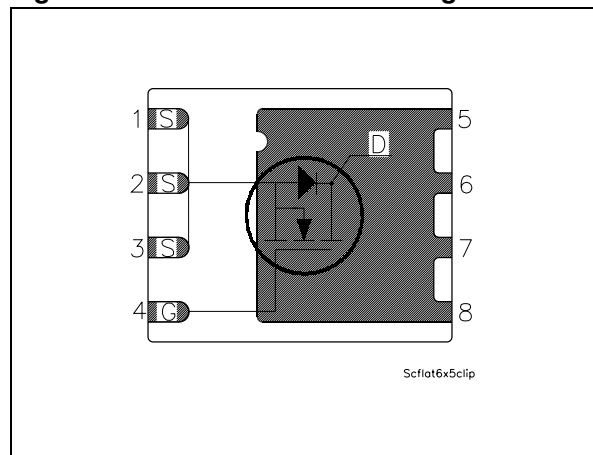

Table 1. Device summary

Order code	Marking	Package	Packaging
STL100NH3LL	L100NH3LL	PowerFLAT™ (6x5)	Tape & reel

Contents

1	Electrical ratings	3
2	Electrical characteristics	4
	2.1 Electrical characteristics (curves)	6
3	Test circuit	8
4	Package mechanical data	9
5	Revision history	11

1 Electrical ratings

Table 2. Absolute maximum ratings

Symbol	Parameter	Value	Unit
V_{DS}	Drain-source voltage ($V_{GS} = 0$)	30	V
$V_{GS}^{(1)}$	Gate-source voltage	± 16	V
$V_{GS}^{(2)}$	Gate-source voltage	± 18	V
$I_D^{(3)}$	Drain current (continuous) at $T_C = 25^\circ\text{C}$	100	A
$I_D^{(3)}$	Drain current (continuous) at $T_C = 100^\circ\text{C}$	71	A
$I_D^{(5)}$	Drain current (continuous) at $T_C = 100^\circ\text{C}$	15.6	A
$I_{DM}^{(4)}$	Drain current (pulsed)	100	A
$I_D^{(5)}$	Drain current (continuous) at $T_C = 25^\circ\text{C}$	25	A
$P_{TOT}^{(3)}$	Total dissipation at $T_C = 25^\circ\text{C}$	80	W
$P_{TOT}^{(5)}$	Total dissipation at $T_C = 25^\circ\text{C}$	4	W
	Derating factor	0.03	W/°C
T_J T_{stg}	Operating junction temperature Storage temperature	-55 to 150	°C

1. Continuous mode
2. Guaranteed for test time $\leq 15\text{ms}$
3. The value is rated according R_{thj-c}
4. Pulse width limited by safe operating area
5. The value is rated according $R_{thj-pcb}$

Table 3. Thermal resistance

Symbol	Parameter	Value	Unit
$R_{thj-case}$	Thermal resistance junction-case (Drain) (steady state)	1.56	°C/W
$R_{thj-pcb}^{(1)}$	Thermal resistance junction-ambient	31.3	°C/W

1. When mounted on FR-4 board of 1inch², 2oz Cu, $t < 10\text{sec}$

Table 4. Avalanche data

Symbol	Parameter	Value	Unit
I_{AV}	Not-repetitive avalanche current	7.5	A
E_{AS}	Single pulse avalanche energy (starting $T_J = 25^\circ\text{C}$, $I_d = 7.5\text{ A}$)	150	mJ

2 Electrical characteristics

(T_{CASE}=25°C unless otherwise specified)

Table 5. On/off states

Symbol	Parameter	Test conditions	Min.	Typ.	Max.	Unit
V _{(BR)DSS}	Drain-source breakdown voltage	I _D = 250 μA, V _{GS} = 0	30			V
I _{DSS}	Zero gate voltage drain current (V _{GS} = 0)	V _{DS} = Max rating, V _{DS} = Max rating @ 125°C			1 10	μA μA
I _{GSS}	Gate body leakage current (V _{DS} = 0)	V _{GS} = ±16 V			±100	nA
V _{GS(th)}	Gate threshold voltage	V _{DS} = V _{GS} , I _D = 250 μA	1			V
R _{DS(on)}	Static drain-source on resistance	V _{GS} = 10 V, I _D = 12.5 A V _{GS} = 4.5 V, I _D = 12.5 A		0.0032 0.004	0.0035 0.005	Ω Ω

Table 6. Dynamic

Symbol	Parameter	Test conditions	Min.	Typ.	Max.	Unit
g _{fs} ⁽¹⁾	Forward transconductance	V _{DS} = 10 V, I _D = 12.5 A		30		S
C _{iss}	Input capacitance	V _{DS} = 25 V, f = 1 MHz, V _{GS} = 0		4450		pF
C _{oss}	Output capacitance			655		pF
C _{rss}	Reverse transfer capacitance			50		pF
Q _g	Total gate charge	V _{DD} = 15 V, I _D = 25 A V _{GS} = 4.5 V <i>(see Figure 8)</i>		30	40	nC
Q _{gs}	Gate-source charge			12.5		nC
Q _{gd}	Gate-drain charge			10		nC
R _G	Gate input resistance	f = 1 MHz Gate DC Bias = 0 Test signal level = 20mV open drain	1	2	3	Ω

1. Pulsed: pulse duration=300μs, duty cycle 1.5%

Table 7. Switching times

Symbol	Parameter	Test conditions	Min.	Typ.	Max.	Unit
$t_{d(on)}$	Turn-on delay time	$V_{DD}=15\text{ V}$, $I_D=12.5\text{ A}$, $R_G=4.7\ \Omega$, $V_{GS}=10\text{ V}$ <i>(see Figure 14)</i>		18		ns
t_r	Rise time			50		ns
$t_{d(off)}$	Turn-off delay time			75		ns
t_f	Fall time			8		ns

Table 8. Source drain diode

Symbol	Parameter	Test conditions	Min	Typ.	Max	Unit
I_{SD}	Source-drain current				25	A
$I_{SDM}^{(1)}$	Source-drain current (pulsed)				100	A
$V_{SD}^{(2)}$	Forward on voltage	$I_{SD}=25\text{ A}$, $V_{GS}=0$			1.3	V
t_{rr}	Reverse recovery time	$I_{SD}=25\text{ A}$, $di/dt = 100\text{ A}/\mu\text{s}$, $V_{DD}=25\text{ V}$, $T_j=150\text{ }^\circ\text{C}$		32		ns
Q_{rr}	Reverse recovery charge			34		nC
I_{RRM}	Reverse recovery current			2.1		A

1. Pulse width limited by safe operating area
2. Pulsed: pulse duration=300 μs , duty cycle 1.5%

2.1 Electrical characteristics (curves)

Figure 2. Safe operating area

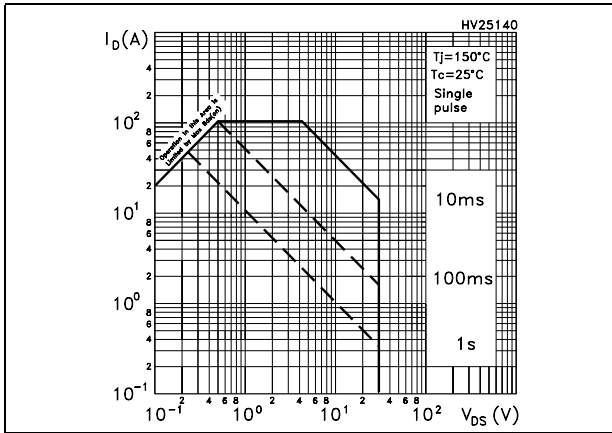

Figure 3. Thermal impedance

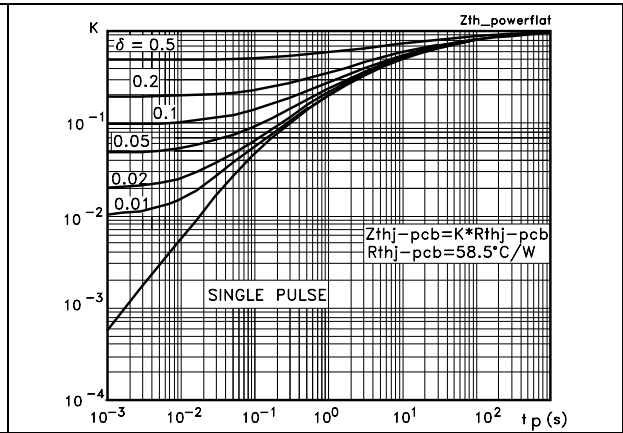

Figure 4. Output characteristics

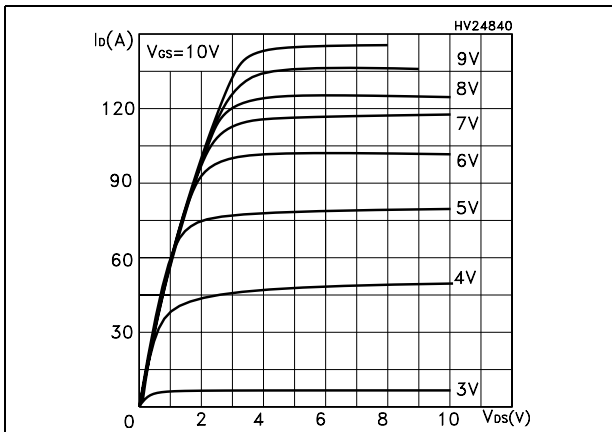

Figure 5. Transfer characteristics

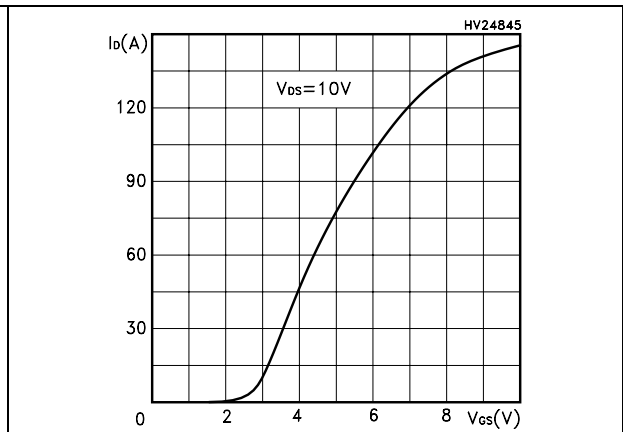

Figure 6. Transconductance

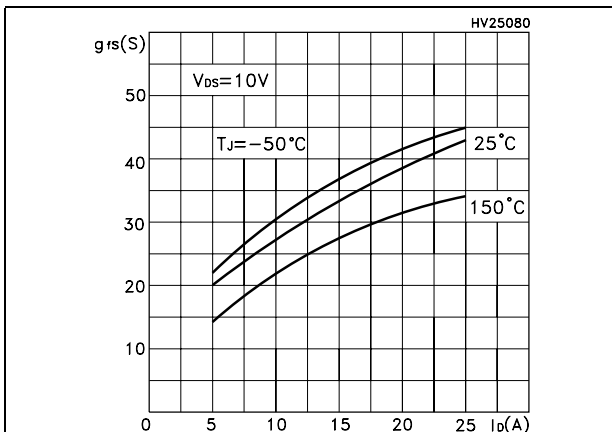

Figure 7. Static drain-source on resistance

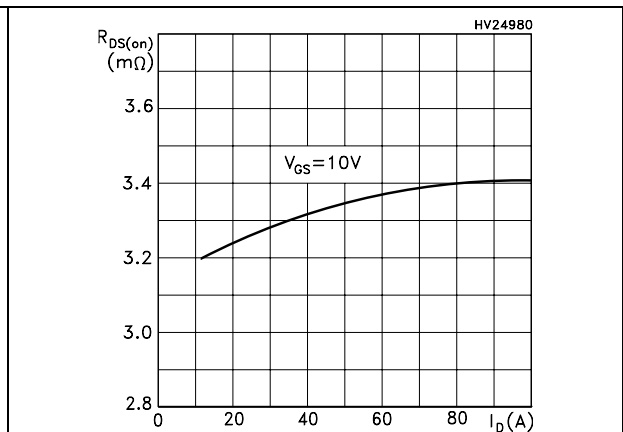

Figure 8. Gate charge vs gate-source voltage Figure 9. Capacitance variations

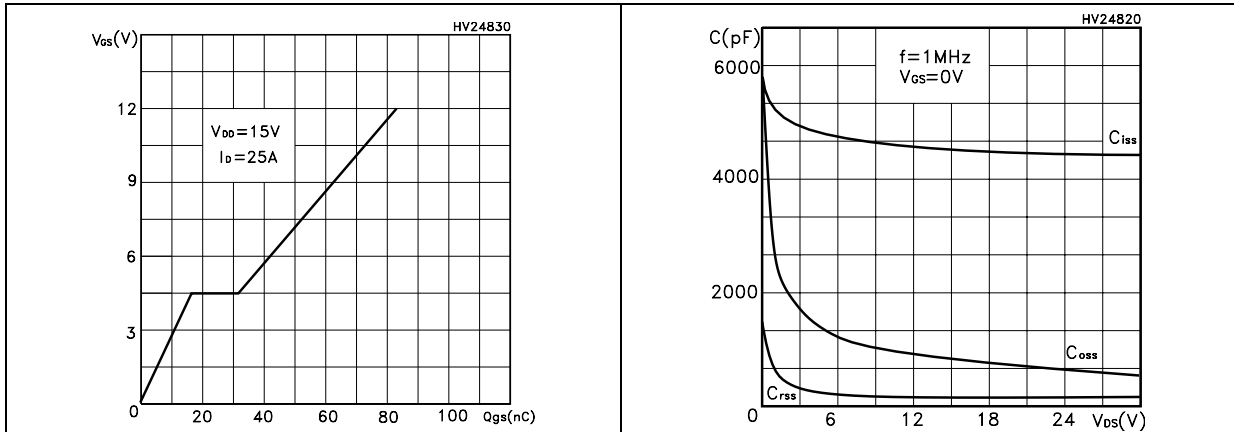

Figure 10. Normalized gate threshold voltage vs temperature Figure 11. Normalized on resistance vs temperature

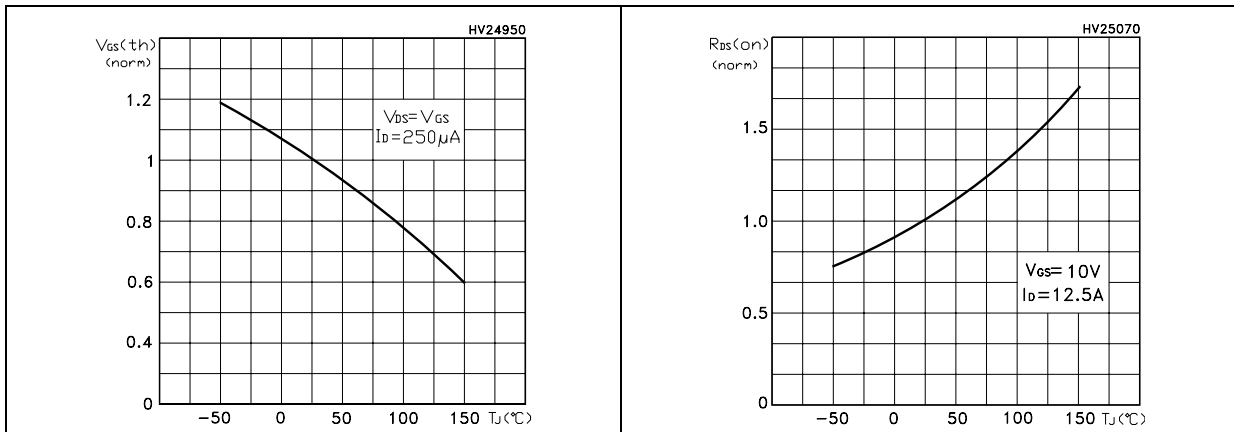
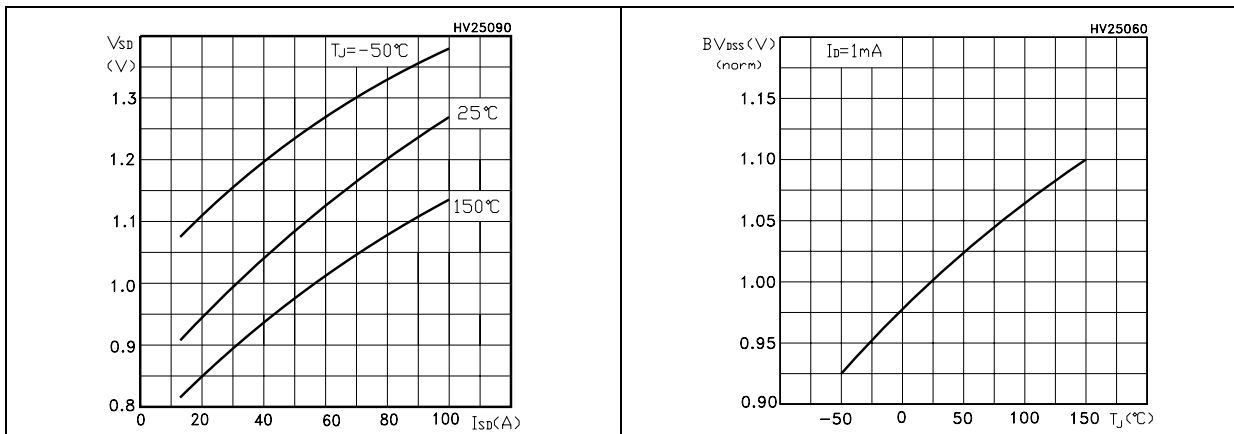

Figure 12. Source-drain diode forward characteristics Figure 13. Normalized $B_{V_{DS}}$ vs temperature



3 Test circuit

Figure 14. Switching times test circuit for resistive load

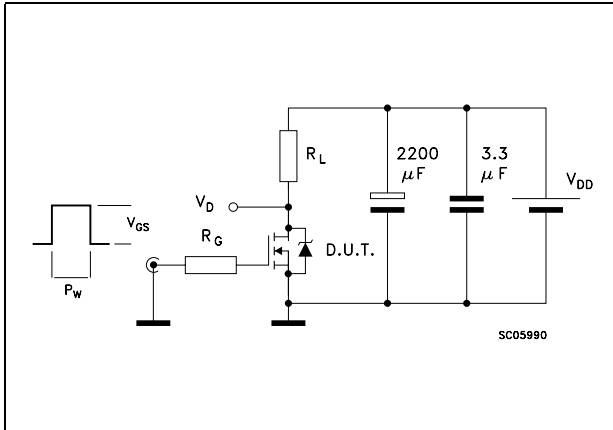

Figure 15. Gate charge test circuit

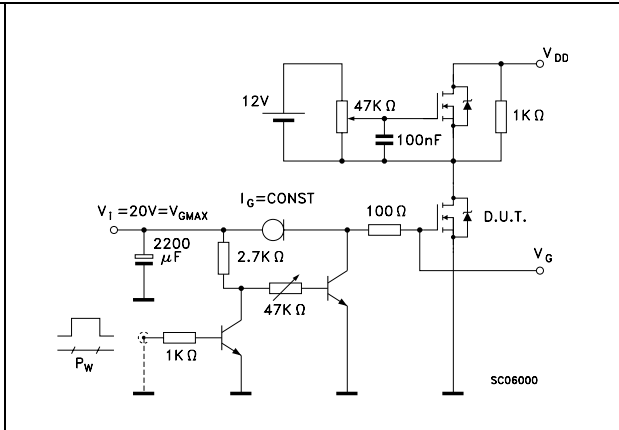

Figure 16. Test circuit for inductive load switching and diode recovery times

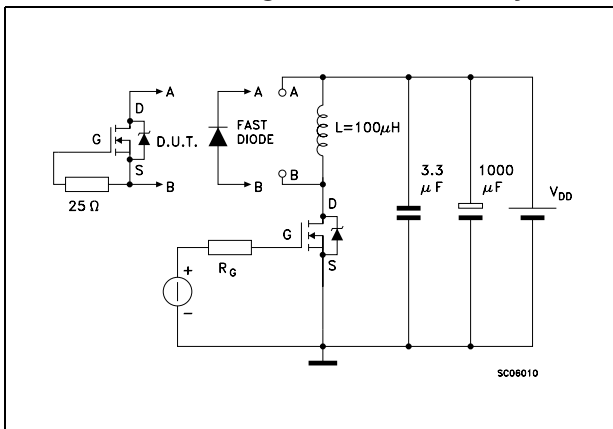

Figure 17. Unclamped inductive load test circuit

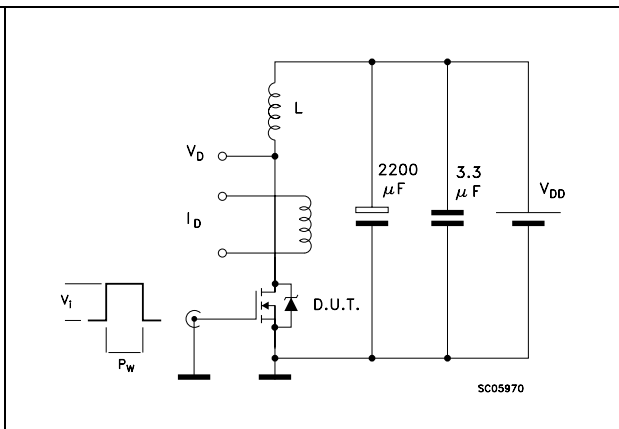

Figure 18. Unclamped inductive waveform

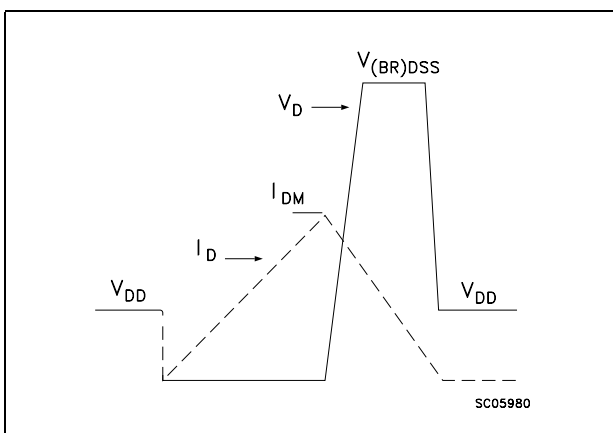
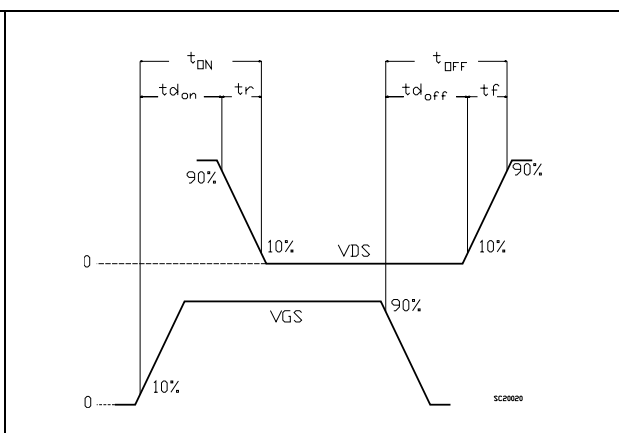

Figure 19. Switching time waveform



4 Package mechanical data

In order to meet environmental requirements, ST offers these devices in ECOPACK® packages. These packages have a Lead-free second level interconnect . The category of second level interconnect is marked on the package and on the inner box label, in compliance with JEDEC Standard JESD97. The maximum ratings related to soldering conditions are also marked on the inner box label. ECOPACK is an ST trademark. ECOPACK specifications are available at: www.st.com

PowerFLAT™ (6x5) MECHANICAL DATA

DIM.	mm.			inch		
	MIN.	TYP	MAX.	MIN.	TYP.	MAX.
A	0.80	0.83	0.93	0.031	0.032	0.036
A1		0.02	0.05		0.0007	0.0019
A3		0.20			0.007	
b	0.35	0.40	0.47	0.013	0.015	0.018
D		5.00			0.196	
D1		4.75			0.187	
D2	4.15	4.20	4.25	0.163	0.165	0.167
E		6.00			0.236	
E1		5.75			0.226	
E2	3.43	3.48	3.53	0.135	0.137	0.139
E4	2.58	2.63	2.68		0.103	0.105
e		1.27			0.050	
L	0.70	0.80	0.90	0.027	0.031	0.035

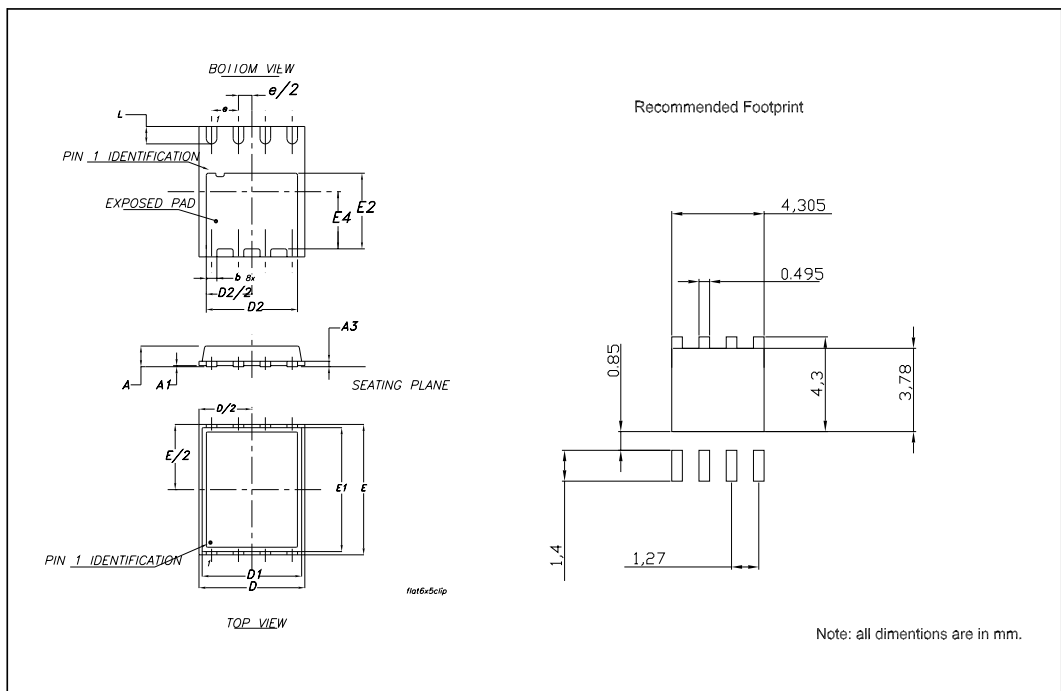

5 Revision history

Table 9. Document revision history

Date	Revision	Changes
18-Apr-2005	1	First Release
20-Jun-2005	2	Updated mechanical data
22-Jun-2005	3	New Rg value on Table 7
10-Oct-2005	4	Inserted ecopack indication
09-Jan-2006	5	New footprint
08-Mar-2006	6	New template
29-Jun-2006	7	Modified curves, see Figure 2 and Figure 3
04-Sep-2006	8	The document has been reformatted, no content change
04-Jan-2007	9	New updated on Table 2
10-Dec-2007	10	Updated data on Table 4: Avalanche data

Please Read Carefully:

Information in this document is provided solely in connection with ST products. STMicroelectronics NV and its subsidiaries ("ST") reserve the right to make changes, corrections, modifications or improvements, to this document, and the products and services described herein at any time, without notice.

All ST products are sold pursuant to ST's terms and conditions of sale.

Purchasers are solely responsible for the choice, selection and use of the ST products and services described herein, and ST assumes no liability whatsoever relating to the choice, selection or use of the ST products and services described herein.

No license, express or implied, by estoppel or otherwise, to any intellectual property rights is granted under this document. If any part of this document refers to any third party products or services it shall not be deemed a license grant by ST for the use of such third party products or services, or any intellectual property contained therein or considered as a warranty covering the use in any manner whatsoever of such third party products or services or any intellectual property contained therein.

UNLESS OTHERWISE SET FORTH IN ST'S TERMS AND CONDITIONS OF SALE ST DISCLAIMS ANY EXPRESS OR IMPLIED WARRANTY WITH RESPECT TO THE USE AND/OR SALE OF ST PRODUCTS INCLUDING WITHOUT LIMITATION IMPLIED WARRANTIES OF MERCHANTABILITY, FITNESS FOR A PARTICULAR PURPOSE (AND THEIR EQUIVALENTS UNDER THE LAWS OF ANY JURISDICTION), OR INFRINGEMENT OF ANY PATENT, COPYRIGHT OR OTHER INTELLECTUAL PROPERTY RIGHT.

UNLESS EXPRESSLY APPROVED IN WRITING BY AN AUTHORIZED ST REPRESENTATIVE, ST PRODUCTS ARE NOT RECOMMENDED, AUTHORIZED OR WARRANTED FOR USE IN MILITARY, AIR CRAFT, SPACE, LIFE SAVING, OR LIFE SUSTAINING APPLICATIONS, NOR IN PRODUCTS OR SYSTEMS WHERE FAILURE OR MALFUNCTION MAY RESULT IN PERSONAL INJURY, DEATH, OR SEVERE PROPERTY OR ENVIRONMENTAL DAMAGE. ST PRODUCTS WHICH ARE NOT SPECIFIED AS "AUTOMOTIVE GRADE" MAY ONLY BE USED IN AUTOMOTIVE APPLICATIONS AT USER'S OWN RISK.

Resale of ST products with provisions different from the statements and/or technical features set forth in this document shall immediately void any warranty granted by ST for the ST product or service described herein and shall not create or extend in any manner whatsoever, any liability of ST.

ST and the ST logo are trademarks or registered trademarks of ST in various countries.

Information in this document supersedes and replaces all information previously supplied.

The ST logo is a registered trademark of STMicroelectronics. All other names are the property of their respective owners.

© 2007 STMicroelectronics - All rights reserved

STMicroelectronics group of companies

Australia - Belgium - Brazil - Canada - China - Czech Republic - Finland - France - Germany - Hong Kong - India - Israel - Italy - Japan - Malaysia - Malta - Morocco - Singapore - Spain - Sweden - Switzerland - United Kingdom - United States of America

www.st.com